



**zefhir**  
by Curti Aerospace Division

Zefhir is the result of modern aerodynamic simulations combined with Italy's tradition of style. Great attention to detail has led to the absolute best geometry for fuselage and tail boom. The airfoil profiles of the main and tail rotor blades ensure low noise emissions and an amazing flight experience.

ASK  
THE SKY

HOW TO BE  
ELEGANT

**zefhir**<sup>Φ</sup>

# ASK THE SKY HOW TO BE POWERFUL

Zefhir represents a real innovation in the two-seater helicopter sector thanks to its modern turboshaft engine. The power plant has a maximum power of 180 kW (241 shp), but is derated to 105 kW (141 shp) leaving ample margins for safety and performance at high altitude and temperatures.

The engine installation is optimized by sophisticated computational fluid dynamic simulations. Its technology is developed by PBS Velka Bites, a.s., a leading manufacturer of aircraft engines in the international aerospace arena for well over 40 years.

The turboshaft engine (gas generator and power turbine) offers great performances: maximum speed reaches 100 knots and cruise speed 87 knots.

The Zefhir logo consists of the word "zefhir" in a lowercase, sans-serif font, with a stylized Greek letter Phi (Φ) positioned above the letter "i".

# ASK THE SKY HOW TO BE SAFE

Zefhir raises the bar for safety in its category. Designed from scratch according to the strictest aeronautical standards, it offers unparalleled safety. The helicopter is equipped with an innovative ballistic parachute rescue system developed in cooperation with Junkers ProFly GmbH and extensively tested as never documented before in the history of aerospace technology. Crashworthy seats and landing gear, an extensive ground and flight testing campaign complete the picture, making Zefhir one of the safest aircraft in its market segment.



**zefhir**<sup>Φ</sup>

# ASK THE SKY

# HOW TO BE LIGHT

Zefhir's power-to-weight ratio makes it a premium high-performance helicopter.

Thanks to careful mass distribution, flight attitude is optimal in any load condition.

The carbon fiber chassis is also incredibly light, just over 70 kg!



The Zefhir logo, consisting of the word 'zefhir' in a blue, lowercase, sans-serif font with a small Greek letter phi symbol above the 'i'.

# ASK THE SKY HOW TO BE UNIQUE

Zefhir was designed by some of the best experts in the helicopter industry. The result is a gem of modern technology and materials, down to its elegant lines and exclusive interiors.



zefhir<sup>Φ</sup>

# ASK THE SKY

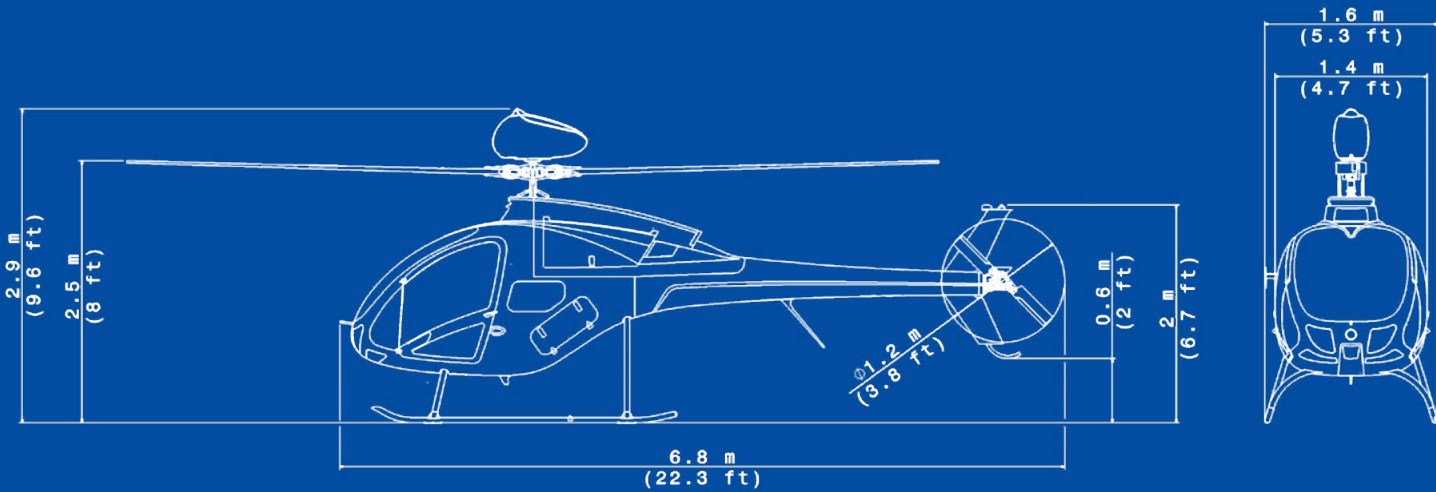

## PERFORMANCE

Maximum takeoff weight	700 kg (1,540 lbs)
Cruise speed	161 km/h (87 kts)
Maximum level speed	185 km/h (100 kts)
Never exceed speed VNE (sea level)	189 km/h (102 kts)
Hovering ceiling OGE (600 kg)	4,000 m (13,100 ft)
Best endurance (10 min reserve)	2hr 15 min @75 km/h (40 kts) Range 169 km (91 nm)
Maximum range (10 min reserve)	318 km (172 nm) @161 km/h (87 kts) endurance 2h

## MAIN ROTOR

Type	Teetering
Number of blades	2
Diameter	7.6 m (24.9 ft)
Chord	195 mm (7.7 in)
Speed	528 rpm

## TAIL ROTOR

Type	Teetering
Number of blades	2
Diameter	1.20 m (3.9 ft)
Chord	120 mm (4.7 in)
Speed	3,062 rpm

# HOW TO BE ADVANCED

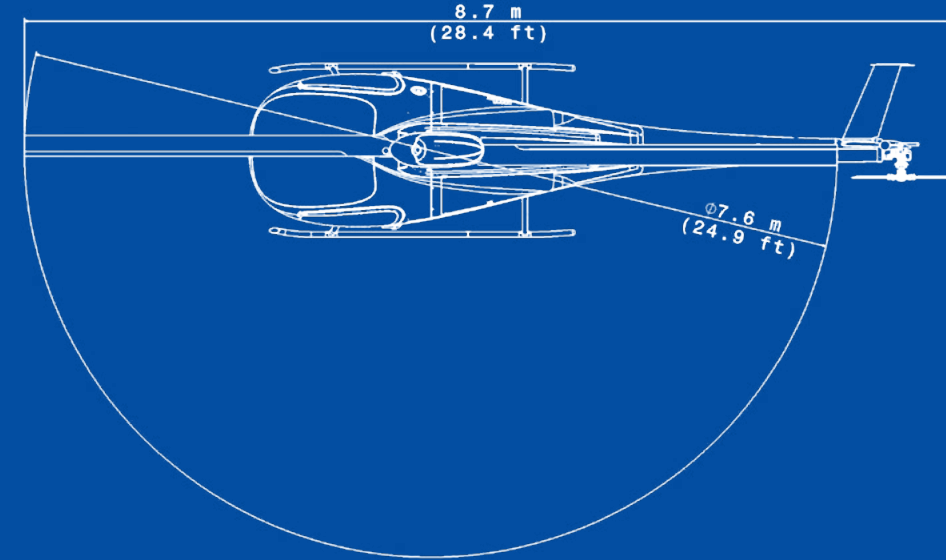

## TRANSMISSION

Primary transmission	Direct
Main gearbox	Bevel spiral gear with a reduction ratio of 12/49
Tail gearbox	Bevel spiral gear with a multiplication ratio of 19/15

## ENGINE

Engine type	PBS TS100 TURBOSHAFT ENGINE (gas generator turbine & power turbine)
Maximum continuous power	105 kW (141 shp)
Output speed	2,158 rpm

## FEATURES

Seating	2 crashworthy seats (according to CS-27)
Cabin width	1.34 m (4.4 ft)
Luggage capacity	320 l (11.3 cu.ft)
Standard fuel capacity	120 l (32 Us gal)
Auxiliary fuel tank available on demand	
Approved fuel type	JET A, JET A-1, JET B according to DERD 2494 TS-1, T2, RT according to GOST 10227

All data reported refers to International Standard Atmosphere (ISA) conditions.  
All data reported is for information purposes only and may be subject to change without notice.

# A DREAM MADE IN **CURTI**

At the heart of the launch of this turbine helicopter lives the passion of the Curti Company with decades of experience in the production of complex parts for certified helicopters.

Matching state-of-the-art materials and technology with the passion for flying that is in the company's DNA.

Challenging design capabilities to achieve maximum safety when airborne.

## **Introducing Zefhir by Curti Aerospace Division.**

A unique turbine helicopter designed to become the brand for the air mobility needs of the future.



**zefhir**<sup>Φ</sup>







via Emilia Ponente 750  
Castel Bolognese  
48014 Ravenna, Italia

Ph +39 0546 655911

info@zefhir.eu  
www.zefhir.eu

 @zefhir\_helicopter

 Zefhir

 Zefhir\_Helicopter

